

WORK INSTRUCTION

DOCUMENT	SLU ON DEMAND FUNCTION DELETE
MACHINE/ GROUP	SANDVIK DD421 JUMBO
DOCUMENT AUTHOR	GAVIN CUNNINGHAM
DOCUMENT NUMBER	MTU10071
DATE	23/02/2026



Background

The latest variation of the SLU system has introduced multiple points of possible failure and service requirement which eventually impact rock lube reliability and effectiveness.

The aim of this modification is to simplify the system and supply lube whenever the pumps and compressor are active`

- This promotes continuous protection to both rockdrills from water and contaminant ingress, e.g while bolting with one boom the other rockdrill would normally not be pressurised and protected from water ingress.
- Simplifies daily and weekly services / lube checks.
- Provides immediate visual and audible signs of water in lube, lack of lube or lack of air.
- Maintains a uniform mix and constant supply of oil/air for rockdrill cooling, lubrication, and contaminant protection.

The 3 points of modification required to implement the change are;

1. Remove air shunt valves under the left step.
2. Change SLU pump pilot pressure from on demand to constant supply (from either boom Stabiliser P port).
3. Change SLUC 24v feed from on demand to constant (powered by PLC compressor output 101CH – 01).

1. The air shunt valves (item 8) are located beneath the LHS stairs.

Remove and isolate the DIN plugs.
Undo the JIC fittings and remove the air shunt valves from the bracket.
Insert spacer MT3862 01 to replace the Shunt valves.

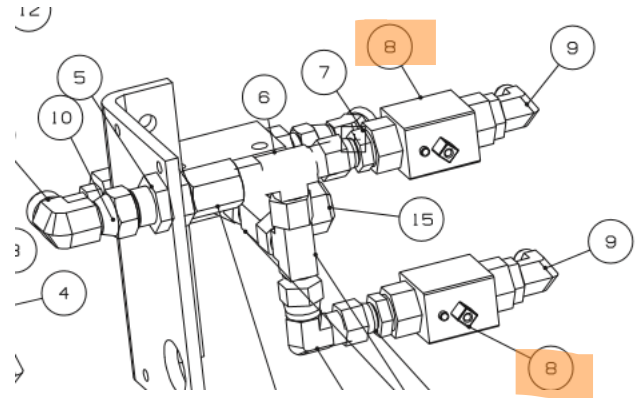

2. Disconnect the SLU percussion oil supply (both booms) from the top of the shuttles near the SLU, these hoses run to the 560 block M3, cap M3, pull both hoses out.

Disconnect the SLU rotation supply (A) and pressure switch hose(B) (2 x -5 JIC connected to the top of the Rotation valve) cap both fittings.
Connect hose A to Stabiliser P Port as per page 3 (2 x -6JICF to -5JICM reducer and 2 x -6 JICT required)

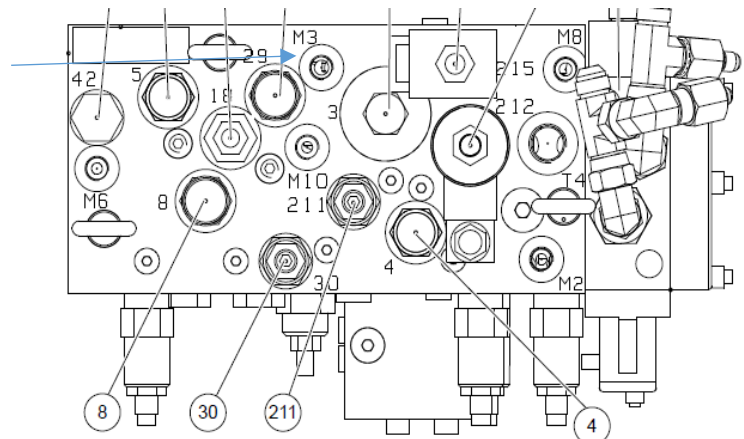

Leave LS -6 From Rot valve to Rot pum connected.

Hose A - Move this hose from the Rotation block to the Stabiliser P port - Page 3 (blow air through to confirm it connects to SLU shunt)

Hose B - Remove the hose from Rot va to the Rot pressure switch and cap this port.

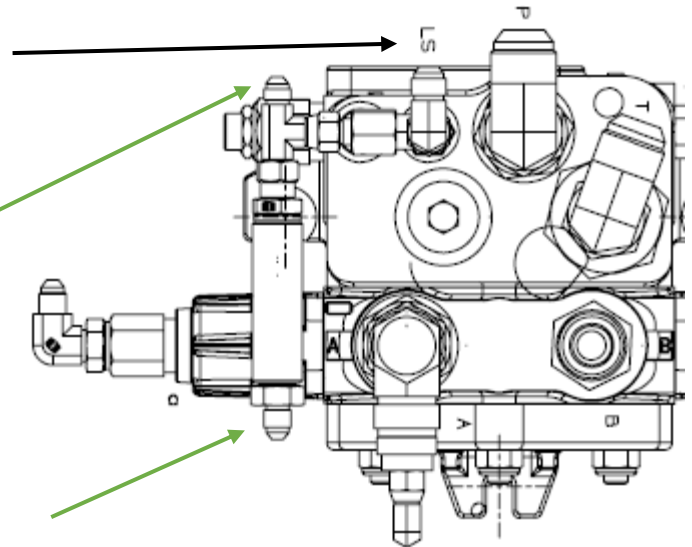

Connect Hose A boom 1 (which supplies the top of the SLU shuttle) using a -6 JIC T to boom 1 stabiliser **P ports**.

Connect Hose A boom 2 (which supplies the bottom of the SLU shuttle) using a -6 JIC T to boom 2 stabiliser **P ports**.

**STAB
P port**

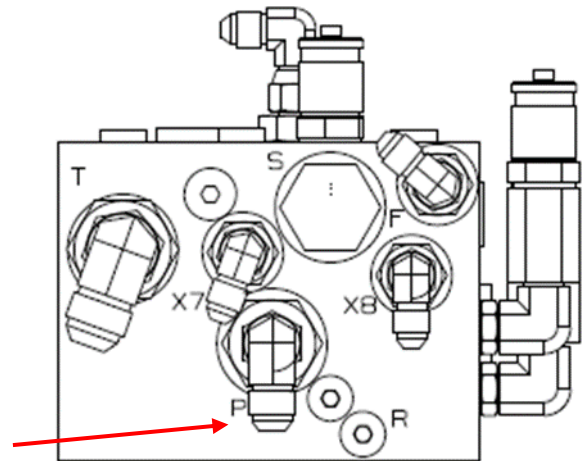

Disconnect all hoses from the inner SLU shuttle and pressure reducing valve. Cap the ports

Remove the rear shuttle.

Connecting Stabiliser **A Boom 1** and **A Boom 2** (from Stabiliser **P** port) to the outer shuttle valve, this will supply P oil to the Pressure reducer from either running powerpack.

Connect the bottom hose from the pressure reducing valve to the P port of both SLU pumps, using a JIC T piece.

Connect the **T** port of the SLU pumps to the T on the Pressure reducer.

T port

P port

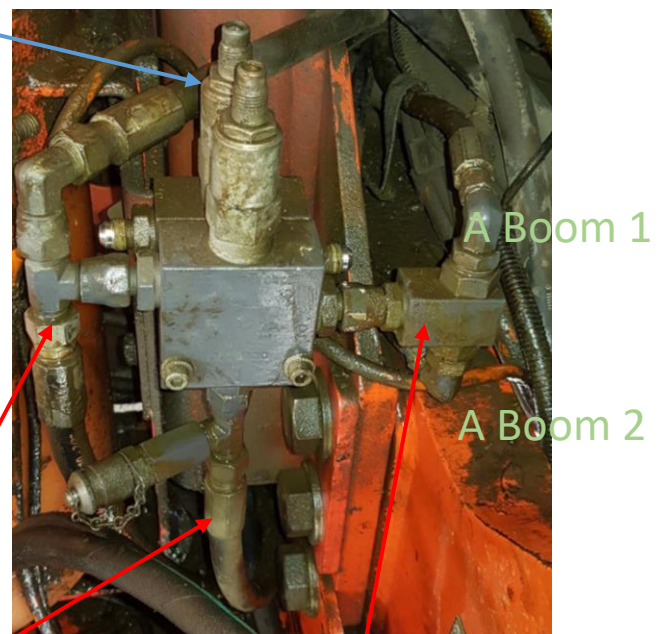

SLU shuttle

3. Make the electrical connections as shown below.

Continuous Lubrication

The compressor output now also switches the SLU to active.

Connected at X500 - 527

Note - when boost is selected on the SLU the compressor will also start, supplying lube air to both Rockdrills.

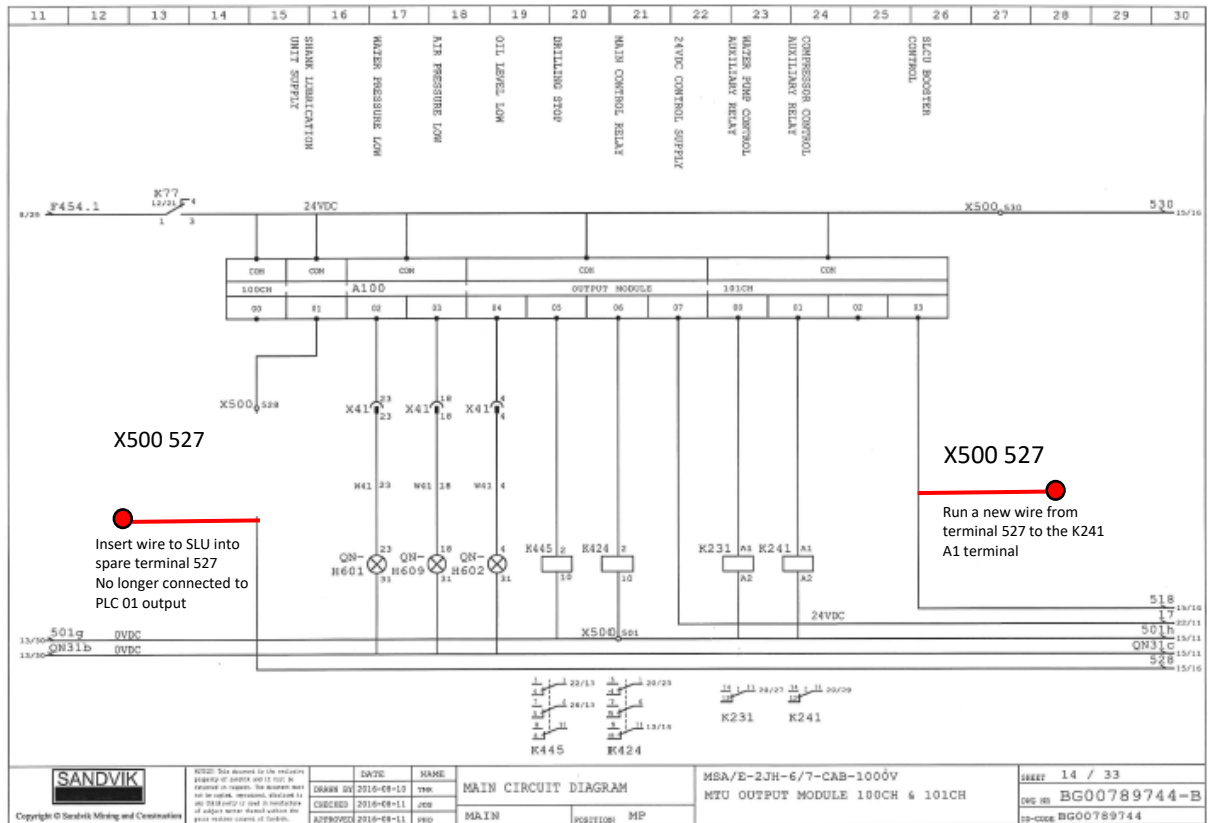

Testing

- Start the compressor and ensure that the SLU solenoid is flashing as per its pre-set timer.
- Connect a pressure gauge to the P port Test 20.
- Start each boom separately, load the pump using Boom extension and check that there is a maximum of 50 bar supplied to the SLU P port.
- Check that the SLU fault light is not active, and that Air and Oil are constantly present at both Rockdrills.