

PRODUCT INFORMATION

DOCUMENT	FEED MANIFOLD
MACHINE/ GROUP	SIMBA E7 / E70
DOCUMENT AUTHOR	Gavin Cunningham
DOCUMENT No.	MTU10194
DATE	19.03.2025



Background

Damage to hydraulic hoses is commonly found when using the OEM hose clamp and feed manifold design. Maintenance Technique's one piece 'L' shaped manifold replaces the OEM arrangement and significantly reduces hose wear / damage.

OEM hoses can be mounted directly to the new manifold, however if re-hosing, a 4m hose length from Boom Manifold to Feed Manifold removes half a meter of loom droop. The loom is then less inclined to catch during rotation and drag on the ground causing accelerated hose wear.

Feed Manifold Overview

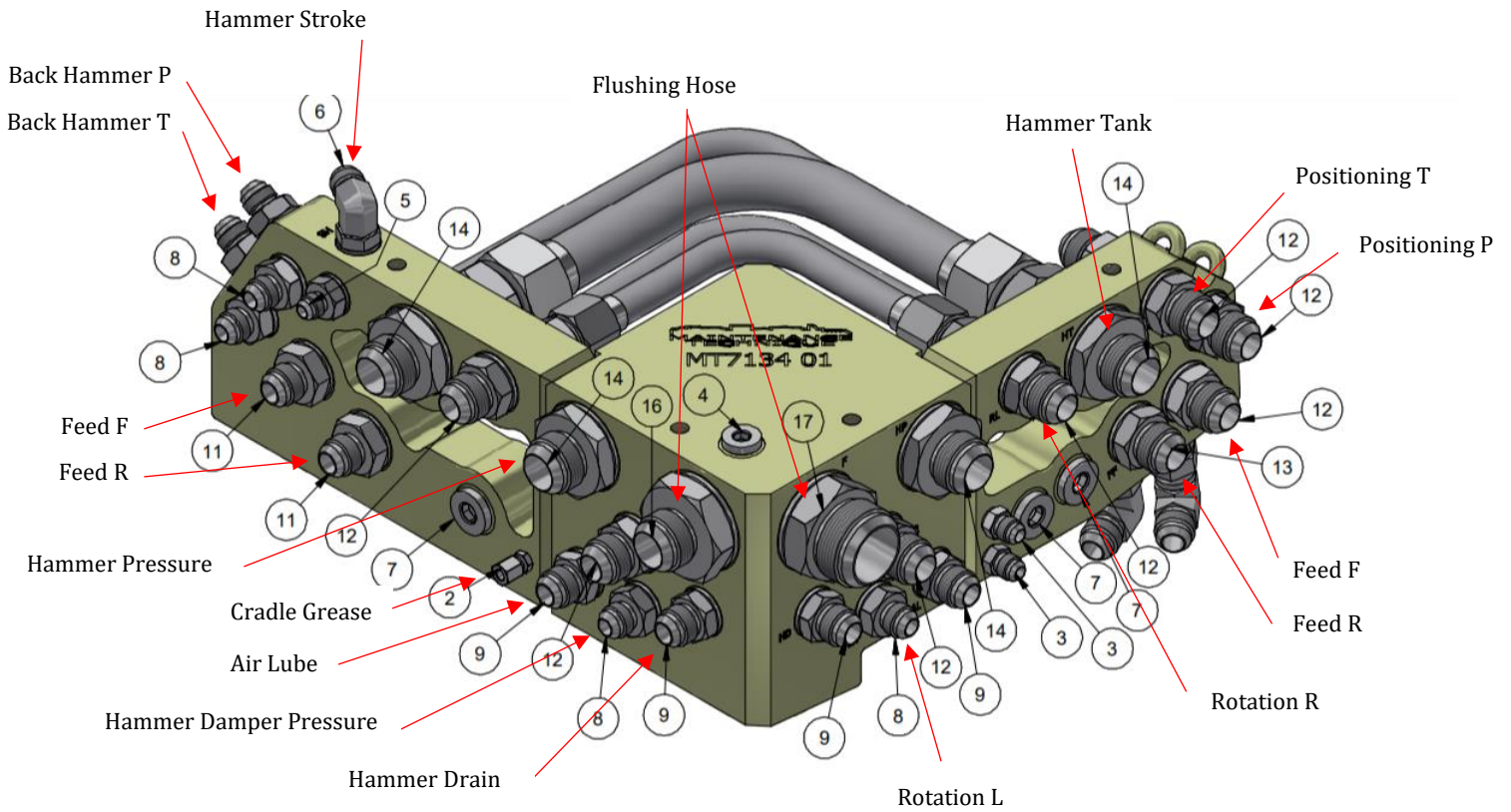

Feed Tilt – Requires Hose Extension

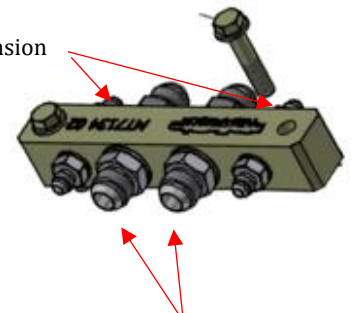

Feed Rotation (Requires Extension Hose)

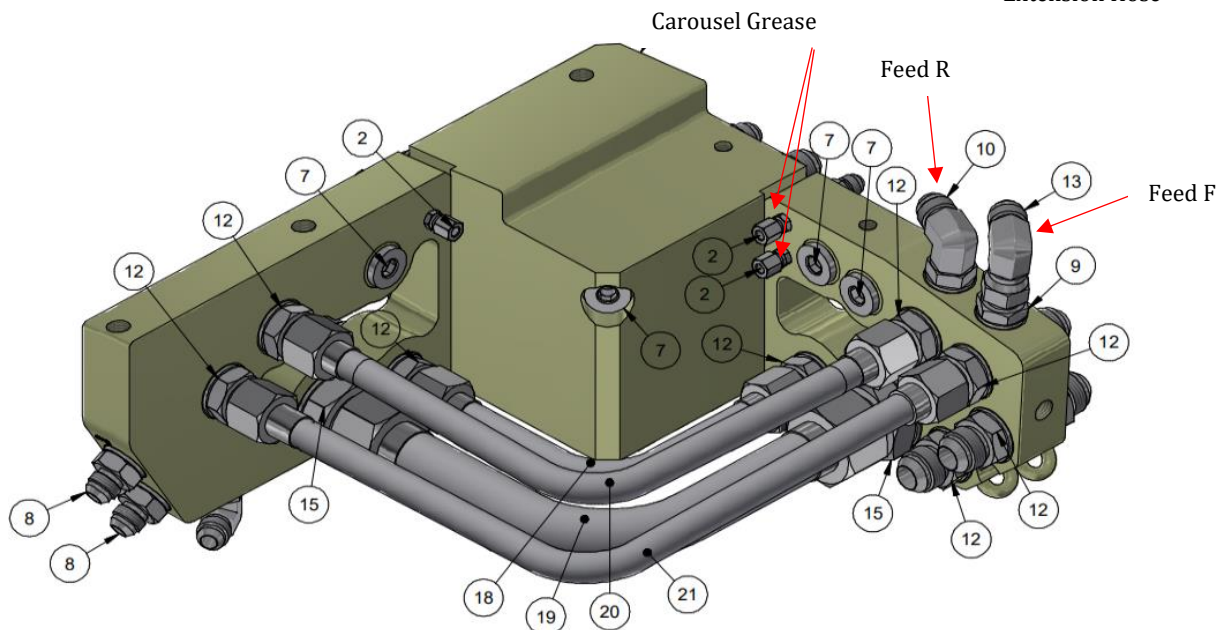

ITEM	PART NUMBER	DESCRIPTION	QTY	COMMENTS
1	MT3128 0030 62	FEED BEAM	1	Includes items 8 - 12
2	MT3128 3097 88	END PLATE COMPLETE	1	Includes items 3 - 7
3	MT3128 3097 88P	END PLATE	1	
4	MT3128 3097 88B	END PLATE ATTACHMENT	1	
5	MT3128 3097 88BS	END PLATE ATTACHMENT SHIM	2	
6	MT0663 2103 67	O-RING	1	
7	MT9236 2002 69	SHIM	2	
8	MT3128 0034 05	SLIDE BAR LEFT	1	
9	MT3128 0034 06	SLIDE BAR RIGHT	1	
10	MT0129 3270 44	BLIND RIVET S/S	28	
11	MT3128 0034 01	CLIP-ON 200 SERIES	2	
12	MT3128 0034 013	CLIP-ON LOCKING ASSEMBLY	2	
13	MT9121 7221 01SX	FEED CYLINDER 1.8m	1	Service ex.
13.1	MT3128 3019 97SX	FEED CYLINDER 1.5m	0	Service ex.
14	MT9122 4332 50	COVER	2	
15	MT9126 2770 50	COVER	2	
16	MT9121 6526 50	FEED CYLINDER SEAL KIT	1	Complete
17	MT3128 0785 74	EXTENSION	2	
18	MT9127 2523 00	PLAIN BEARING	1	
19	MT9126 2714 00	PIPE	1	
20	MT3128 3097 99	SENSOR BRACKET	1	
21	MT3128 0030 19	PROTECT COVER	1	
22	MT9111 0004 06	HOSE BRACKET	1	
23	MT3128 3161 62	ATTACHMENT	1	
24	MT3128 3098 12	CLAMP	2	
25	MT0147 1496 03	SCREW M16x160 HexHd	12	
26	MT3128 3098 13	ATTACHMENT	1	
27	MT7134 01B	BRACKET	1	
28	MT7134 02	BULKHEAD	1	
29	MT7134 01FK	FITTINGS KIT	1	
30	MT7134 PT	HYDRAULIC PIPE	1	
31	MT7134 RL	HYDRAULIC PIPE	1	
32	MT7134 FF	HYDRAULIC PIPE	1	
33	MT7134 FR	HYDRAULIC PIPE	1	
34	MT7134 01	FEED MANIFOLD	1	
35	MT3128 0037 00	DAMPING	1	
36	MT0147 1959 28	SCREW M30x150 HexHd	1	
37	MT0147 1492 03	SCREW M16x120 HexHd	8	
38	MT9106 2192 17	LINEAR SENSOR RCS4	1	
39	MT3128 3097 27	LINEAR SENSOR RCS3	1	2.4m cable

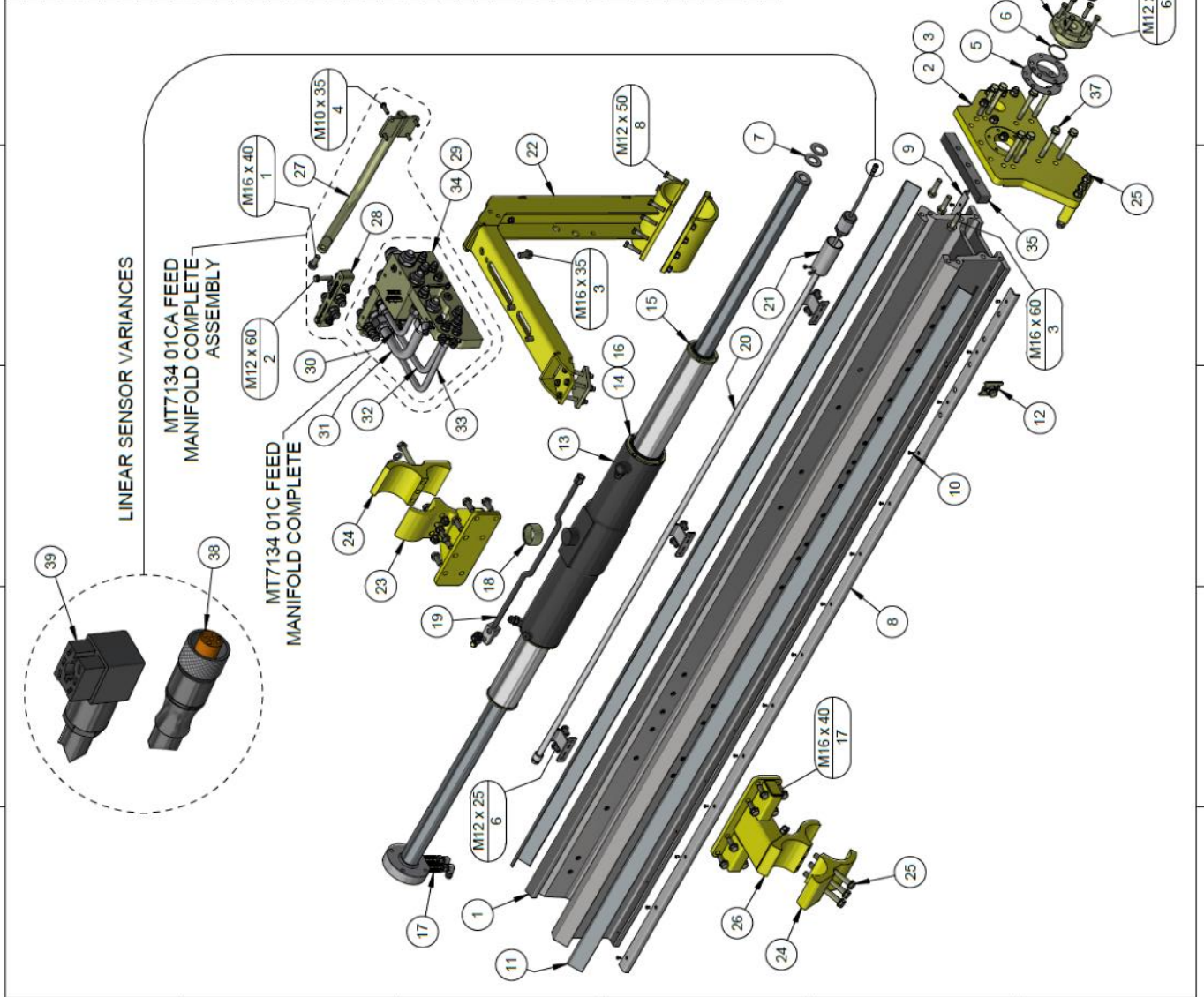

PART NUMBER: **MT3128 0020 26-3** DESCRIPTION: **FEED REAR**



MT Parts: 0407 059 610
1 Hakeey Circuit, Roseworthy, S.A. 5371
171 Dugan Street, Kalgoorlie W.A. 8430
parts@mtunderground.com PAGE
www.mtunderground.com 2.3

