

[221031]

HOSE LENGTHS 1838 – ME7C

To Suit MT9772 0145 25C - HOSE GUIDE COMPLETE
With angle bracket – item 10

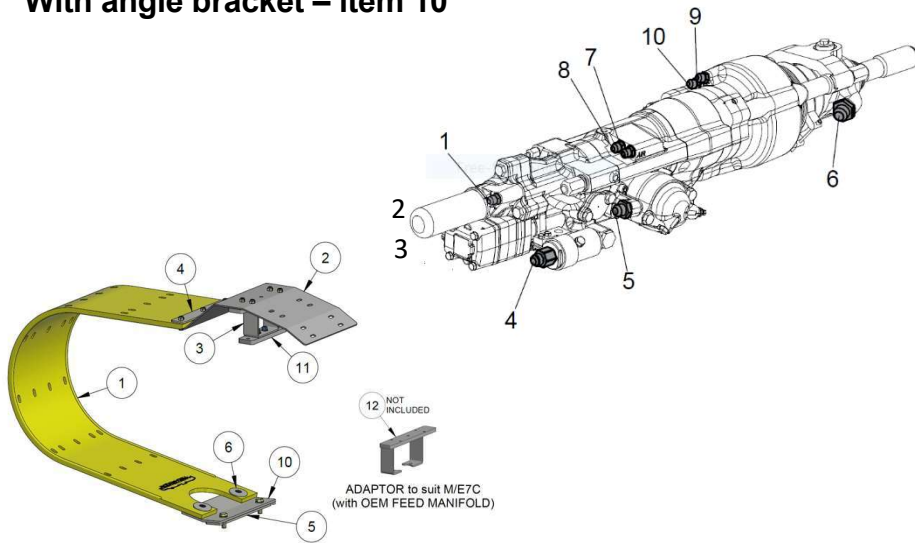

HOSE	HOSE SIZE	JIC HOSE TAIL	CUT LENGTH WITHOUT ANGLE BRACKET (ITEM 10)	CUT LENGTH WITH ANGLE BRACKET (ITEM 10)	INFO
WF	1"	-16	2940MM	3040MM	6-WATER FLUSHING
HP	¾"	-12	2280MM	2380MM	5-HAMMER PERC
HT	1"	-16	2180MM	2280MM	4-HAMMER TANK
BHP	3/8"	-8	2650MM	2750MM	10-EXTRACTOR PRESSURE
BHT	½'	-10	2650MM	2750MM	9-EXTRACTOR TANK
HD	½	-10	1960MM	2060MM	1-HAMMER DRAIN
HDP	3/8"	-8	2300MM	2400MM	8-DAMPENING
AL	3/8"	-10	2300MM	2400MM	7-AIR LUBE
FF	½	-10	2760MM	2860MM	FEED LEFT OF CYLINDER
FR	½	-10	2800MM	2900MM	FEED RIGHT OF CYLINDER
RL	¾	-12	1960MM	2060MM	2-ROTATION TOP (with 45deg elbow)
RR	¾	-12	1960MM	2060MM	3-ROTATION BOTTOM (with 45deg elbow)
GREASE	¼	-4	2350MM	2450MM	GREASE USE 90 DEGREE FITTING IN CRADLE. RUN UNDER DRIFTER TO RHS DISTRIBUTOR

ITEM	PART NUMBER	DESCRIPTION
1	MT9772 0145 25	MAT
2	MT9772 0145 25B	BENT ATTACHMENT
3	MT9772 0145 25M	MOUNT
4	MT9772 0145 25P	CLAMPING PLATE
5	MT9772 0145 25S	MAT SPACER
6	MT9772 0145 25W	WASHER
10	MT9772 3060 7CBA	BOTTOM ADAPTOR (ANGLE BRACKET)
11	MT9772 0130 60	ADAPTOR PLATE
12	MT9772 0145 257	MOUNT