

MT PRODUCT INFORMATION

MT 3222 3314 6664

DOCUMENT	MT HD PRESSURE PUMP UPGRADE
MACHINE/ GROUP	ALL UNDERGROUND DRILLS
DOCUMENT AUTHOR	GORDON TAYLOR 0468 930 409
DATE	20/12/2022

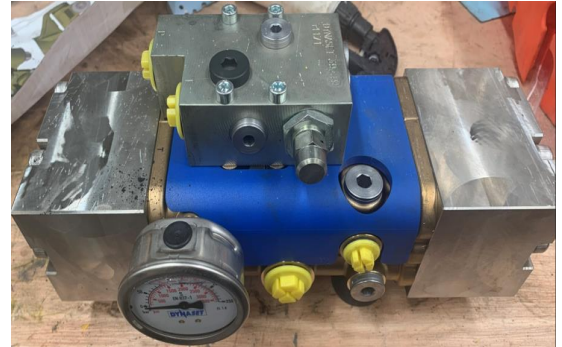

Background

The high pressure dynaset water pump used on underground drills has 3 small vent holes (to atmosphere) between the high-pressure water seal and the piston hydraulic seal. When the single water seal fails, these vents are insufficient in size for the flow created and eventually calcify closed. This leads to water forcing through to the hydraulic chamber each time the pump piston switches direction. As a result, high pressure water enters the hydraulic system and contaminates the oil.

Maintenance Technique manufacture and fit custom water pistons made from stainless steel and larger stainless steel pumping ends. The new pump ends incorporate an additional water seal and multiple large vents to prevent water ingress into the hydraulic system in the event of a seal failure.

The service life of the pump is improved in comparison to standard pumps; however, hydraulic contamination does not occur upon seal failure and the pump ends can be re-sealed economically using (MT3222 3314 668 RESEAL SET MT DYNASET WATER END)

The original dynaset pump body is retained and therefore we utilise a bronze body pump for hard water conditions.

Contact parts@mtunderground.com for more information or pricing.

ITEM	PART NUMBER	DESCRIPTION	QTY	COMMENTS
1	MT3222 3314 66CB	HIGH PRES. HYDR. WATER PUMP	1	
2	MT3222 3314 6663	MT HD UNIT UPGRADE KIT	1	incl. items 3 to 9
3	MT3222 3314 141	MT HD UNIT END CAP (RHS)	1	Stainless Steel
4	MT3222 3314 151	MT HD UNIT END CAP OH (LHS)	1	Stainless Steel
5	MT3222 3314 193	MT HD UNIT PUMP PISTON	2	Stainless Steel
6	MT3222 3314 6662	BOLT	10	Stainless Steel
7	MT3222 3314 666	VALVE SET - WATER	1	
8	MT3222 3314 668	PUMP SEAL KIT	1	
9	MT3222 3314 662	REVERSAL VALVE GUIDE	1	

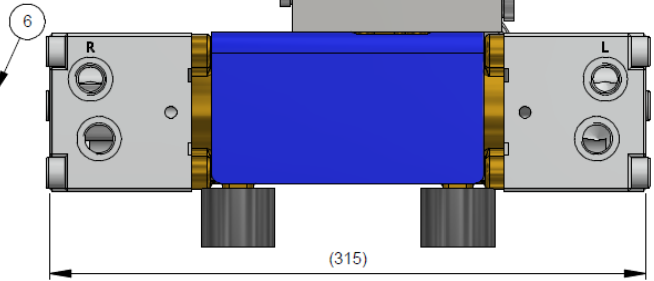
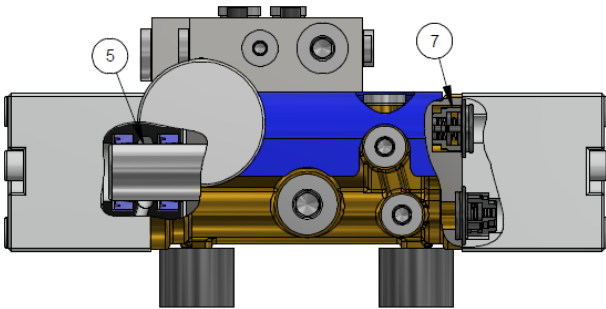
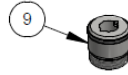
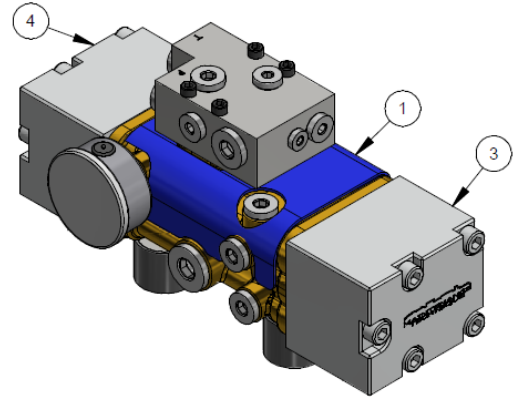

PART NUMBER MT3222 3314 6664	DESCRIPTION MT HD PRESSURE PUMP
	MAINTENANCE TECHNIQUE <small>UNDERGROUND DRILL RELIABILITY</small>
MT Parts: 0407 059 610 1 Halesby Circuit, Roseworthy S.A. 5371 171 Dugan Street, Kalgoorlie W.A. 3400 parts@mtunderground.com www.mtunderground.com	

