

MTSWI No.	MT210312	Date -	12/06/2021	Version – 1.3
Task	S Simba Feed and Boom hose lengths			Timeframe – 2hrs

Materials Required

1. .Training Evidence Booklet
2. .MT Training manual
3. .Revise MSDS
4. .
5. .
6. .
7. .





Equipment and tools

1. .Machine/workbench
2. .Tags
3. .PPE as required
4. ..Spanner set
5. .Specific port plugs and caps
6. . Drain tray

SAFETY MUST BE YOUR FIRST PRIORITY

SAFE WORK INSTRUCTIONS

S Simba Feed and Boom hose lengths

	Carefully read through relevant machinery information before use		Enclosed steel capped footwear must be worn at all times
	Safety eyewear must be worn at all times		Gloves must be worn if working with high pressure oils, not with rotary equipment
	Hearing protection must be worn		









WARNING
HIGH PRESSURE OIL can cause severe injury.
 Disconnect power and drain accumulator before servicing hydraulic system.





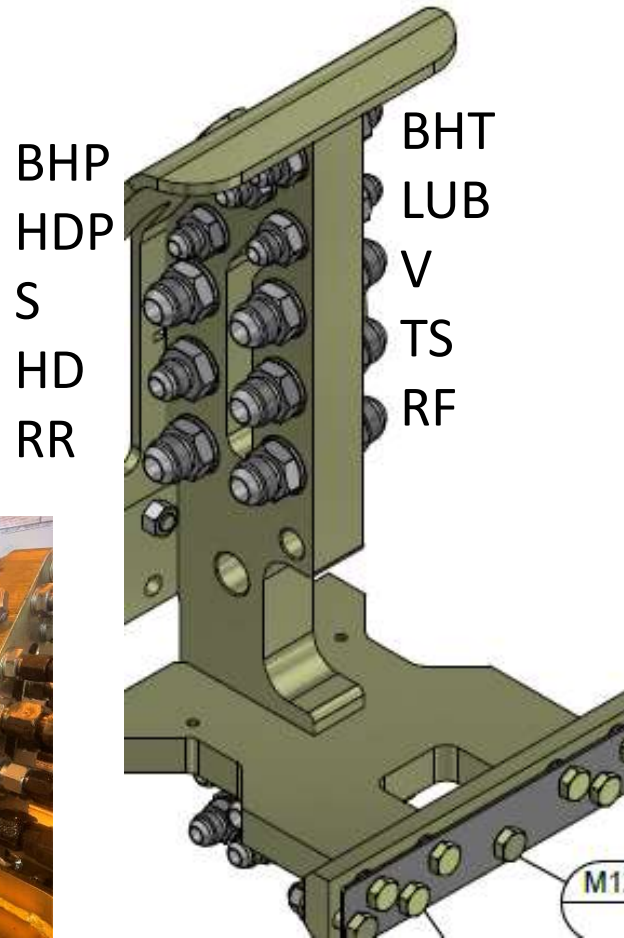

S7C Hose Tree to ROCKDRILL Lengths 1.8M Rod Feed

All hoses within this document are measured to the cut length of the hose, and with the use of the MT 3 tier cotton reel MT3128 0475 10E.

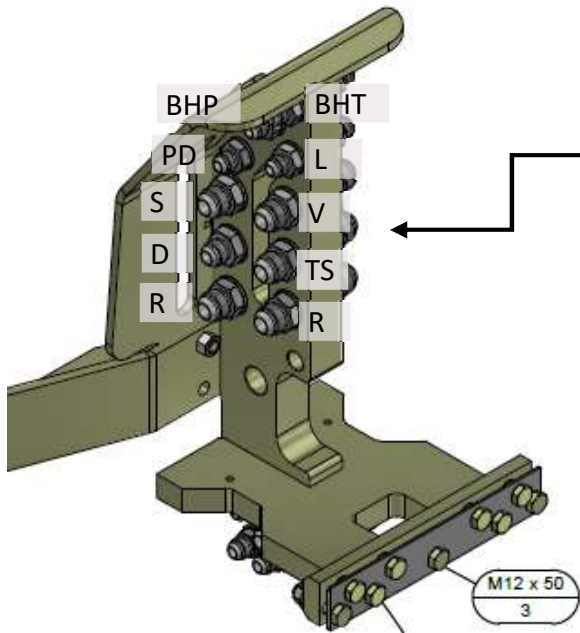

Bulkhead top to bottom	Total length	Hose size	Jic size
BHP3 Extractor BHP BHT3 Extractor BHT	2900	-6 -8	-8 -10
Damper HDP	2530	-6	-8
Lube LUB	2530	-6	-8
Perc Pressure S	2530	-12	-12
Perc Return TS	2440	-12	-12
Drain HD	2900	-8	-10
Front Rotation RF Rear Rotation RR	2730 2620	-12	-12
Flushing V	3130	-12	-12
Feed Top port Feed Lower port	1990	-8	-10

**Right side Feed hoses
Need 90Deg view**



Hose name	Total length	Hose size	Jic size
S2 Perc T TS2 Perc P	2.9	-12	-12
R64Rot Front R3 Rot Rear	2.8	-12	-12
BHP3 Extractor P BHT3 Extractor T	2.9	-6	-8
F4 Feed Front F3 Feed Rear	2.7	-8	-10
V2 Flushing	2.8	-12	-12
L32Lube	2.8	-8	-10
D2 Drain	2.8	-8	-10
PD2 Damper P	2.8	-6	-8
AR Auto Return # DCS only	2.7	-4	-6

DS3 BSH jaws DS4	4.2 4.2	-6	-8
FE3 Feed Ext FE4	2.5 2.5	-6	-8
RA3 Rod swing RA4	3.4 3.4	-4	-6
MR5 Rod grip MR6	3.4 3.4	-4	-6
RG3 Rod grip RG4	3.4 3.4	-4	-6
SR3 Stinger Rear SR4	3.3 3.3	-6	-8
SF3 Stinger front SF4	3.3 3.3	-6	-8
FL1 Feed Lookout FL2	3.3 3.3	-4	-6
FR1 Feed Swing FR2	.9 1.2	-4	-6
BOR1 Rollover BOR2	1.3 1.3	-4	-6

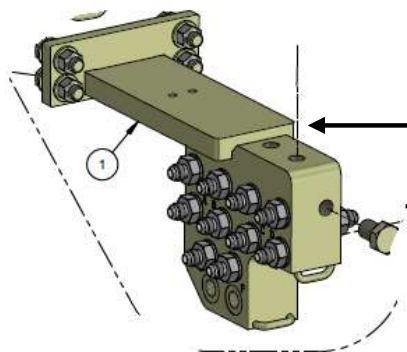

Left side Boom hoses

