

MTSWI No.	MTSWI210121	Date -	21/01/2021	Version – 1.1
Task	Install MT S7C Carousel Control Kit			Timeframe – 2 hrs.



- Materials Required
1. .System reference
  2. .Take-5 or equivalent
  3. .
  4. .
  5. .
  6. .
  7. .

- Equipment and tools
1. .Machine
  2. .PPE as required
  3. .Spanner set
  4. .Hydraulic plugs and caps
  5. .
  6. .
  7. .

# SAFETY MUST BE YOUR FIRST PRIORITY

## SAFE WORK INSTRUCTIONS

### Install MT S7C Carousel Control Kit

	Carefully read through relevant machinery information before use		Enclosed steel capped footwear must be worn at all times
	Safety eyewear must be worn at all times		Gloves must be worn if working with high pressure oils, not with rotary equipment
	Hearing protection must be worn		







**WARNING**  
**HIGH PRESSURE OIL** can cause severe injury.  
 Disconnect power and drain accumulator before servicing hydraulic system.





MTSWI No.	MTSWI210121	Date.	21/01/2021	Version - 1.2
-----------	-------------	-------	------------	---------------

Task	Install MT S7C Carousel Control Kit
------	-------------------------------------

**Background** – The operation of the carousel fitted to the S7C, has a very fine adjustment on the hall effect sensor fitted at the drive motor. It has been found that the length of hose from the DCV fitted at the RHS of cab, to the carousel, has an accumulator effect and can cause overrun of the carousel when DCV is de-activated. This in turn causes the carousel to stop past the intended position, thus causing rod handling issues. Excessive speed adjustment of the flow control, also causes the same fault. MT recommends changing and upgrading the position of the double check valve, from beneath the DCV at the cab, to the bulkhead mounted on the rail between the gripper arms, and fitment of x2, .6 restrictors at the double check valve.

- **Step 1. Remove OEM double check valve.**
  - Release any stored energy remaining in circuit.
  - Open cabinet door at RHS of cab, see (fig. 1).
  - Locate Y303 (see fig. 1) and remove valve stack.
  - Remove double check valve from bottom of valve stack, discard M5x130mm caps crews. Refit DCV and flow controller using M5x90mm cap screws supplied, ensuring flow control valve and adapter plate are refitted in the same orientation they were removed.
  
- **Step 2. Fit Double Check Valve and Restrictors.**
  - Remove hoses MR1 and MR2 from the bulkhead fitted between the gripper arms.
  - Using x2 ½" BSPP – -6 JIC female/swivel fittings, fit the new double check valve to the bulkhead.
  - Fit the x2 supplied .6 restrictors to the outlet ports of the double check valve and refit the removed hoses.

Fig. 1

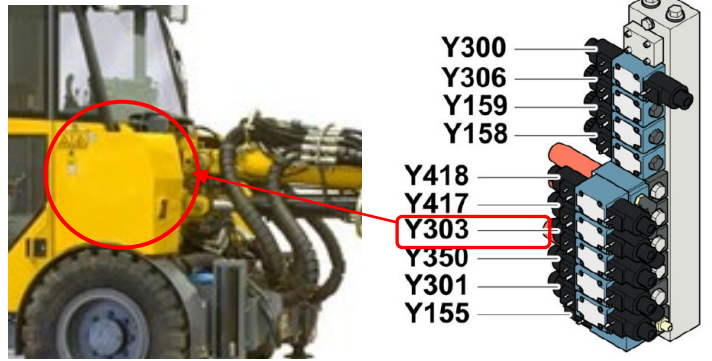

Fig. 2

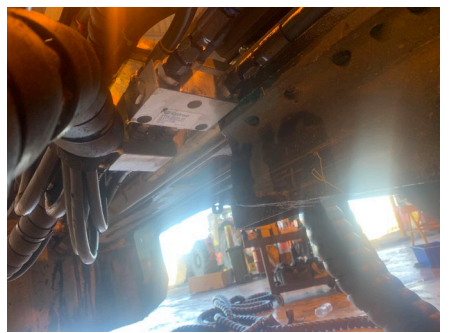

Fig. 3

MTSWI No.	MTSWI210121	Date.	21/01/2021	Version - 1.2
Task	Install MT S7C Carousel Control Kit			

- **Step 3. Check and Adjust Carousel Speed**

- With a minimum of 3 rods loaded in carousel, rotate the carousel in rod remove mode (counter-clockwise) 3-4 times. The operation of the carousel should be smooth with an index time of 2-4 seconds, from the moment the index button is pressed, to the moment the carousel stops turning.
- **NOTE: If index time is less than 2 seconds, the carousel may overrun it's stop positions and will not drill in one hole auto or pull rods in auto. Anything over 4 seconds may cause the carousel to time out.**
- Operate the carousel in rod add mode (clockwise) with gripper arms in carousel, and jaws open, the carousel should take the same number of movements to reach the gripper arms and should stop with a rod resting in the stationary jaw. The LED indicator light fitted to the carousel position sensor should also be lit, if it is not fitted with an LED indicator plug, you can view the carousel sensor from the RCS screen, it should indicate a "1". if it lights up and then turns off, or the "1" appears and disappears, the carousel is too fast and needs to be slowed. This can be done via the flow controller located beneath DCV Y303, as shown in fig.1.
- Adjustment of the flow controller is opposite to the coil being activated, i.e., if Y303 B is activated, adjust the screw beneath Y303 A.
- Close the gripper jaws, the carousel should not be loaded when the jaws are closed, and the LED indicator should remain on. If LED indicator turns off and load placed on carousel when closing the jaws, the hall effect sensor on the drive motor requires adjustment.

Fig. 1

Flow controller is mounted directly beneath DCV

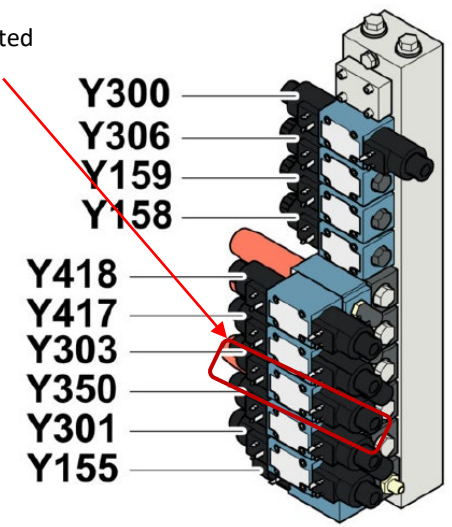

X2 -6 restrictors must be fitted, if these are not in place, operation of the carousel will not be smooth.

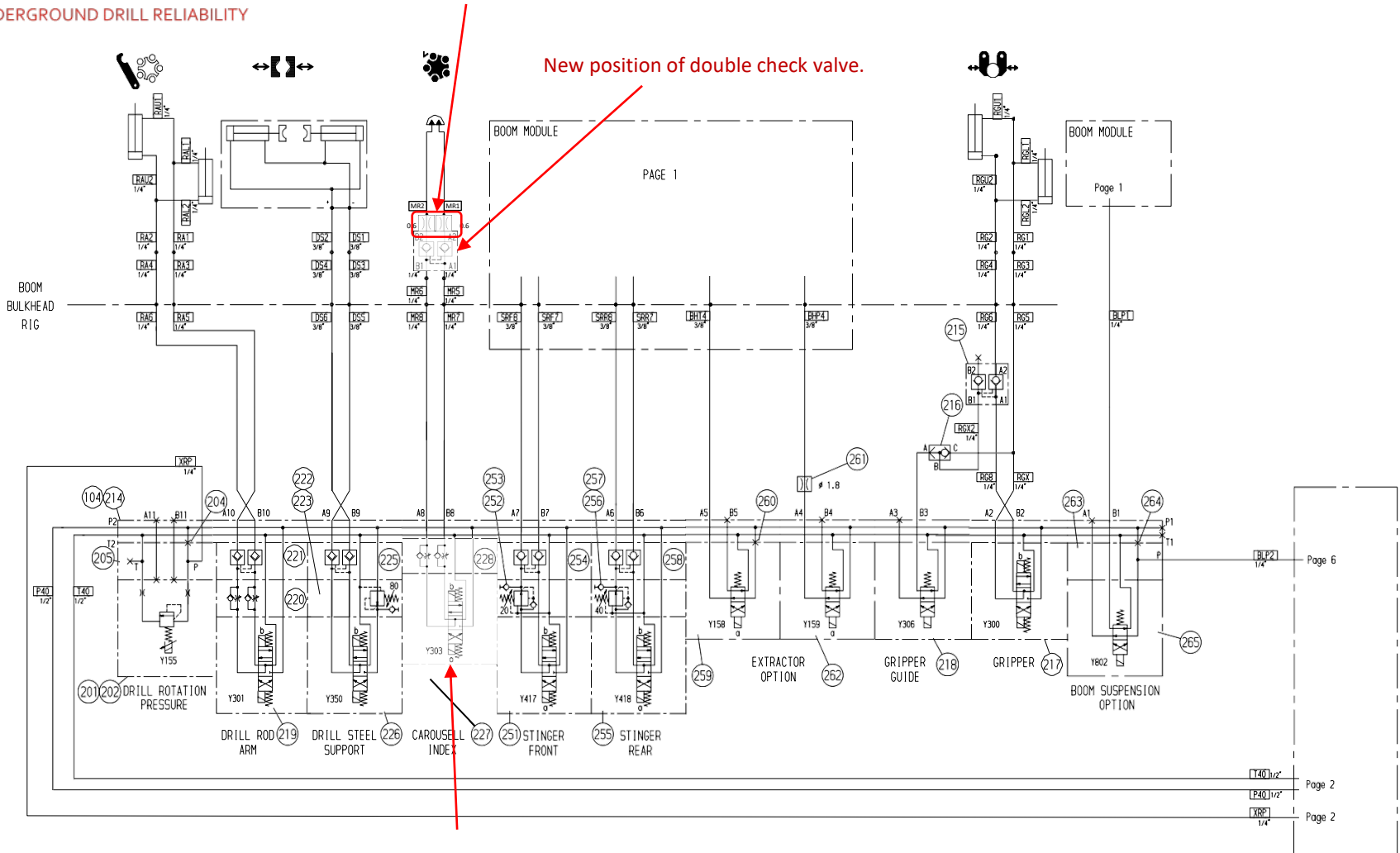

DCV & flow valve, showing double check valve removed.



ITEM	PART NUMBER	DESCRIPTION	QTY	COMMENTS
1	MT3128 3158 86	ROD HANDLER HOSE TREE BASE	0	
2	MT3128 3158 86P	ROD HANDLER HOSE TREE COVER	0	
3	MT9106 2478 2W	INPUT ADAPTOR - TWO WAY	1	
4	MT9106 2483 4W	INPUT ADAPTOR - FOUR WAY	1	
5	MT9106 2483 2C	PROTECTION COVER	1	
6	MT3128 2538 18	GREASE DISTRIBUTOR BLOCK	1	12 port - refer page 1.15
7	MT1110 0023 31	CLAMP	2	
8	MT9106 0630 10	DOUBLE CHECK VALVE	1	
8.1	MT4090 0630 00	M5 x 90 SHCS	4	For the removal of OEM double check valve
9	MT3217 6513 01	RESTRICTOR	2	0.6mm
10	MT1211 1227 015	SIGNAL CABLE	4	1.5m gripper input
11	MT9106 1511 51	LED SIGNAL CABLE	1	1.5m caro input LED
12	MT1211 1221 015	SIGNAL CABLE	1	1.5m csro input
13	MT1211 1221 045	SIGNAL CABLE	1	4.5m linear sensor
14	MT2320 2320 115	SIGNAL CABLE	2	11.5m boom cable
15	MT9106 2478 30	SIGNAL CABLE	2	
16	MT3128 3158 FK	FITTINGS KIT	1	Includes 16 x nipple

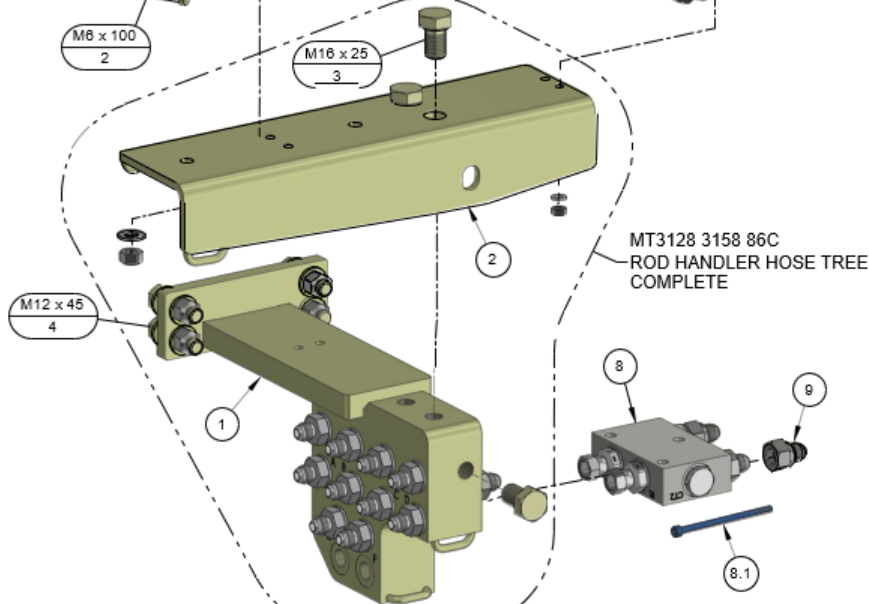
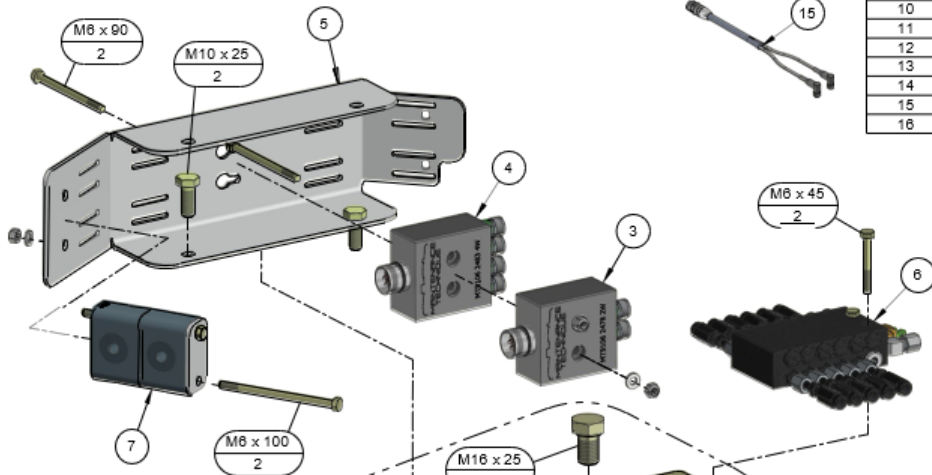

MT3128 3158 86C  
ROD HANDLER HOSE TREE  
COMPLETE

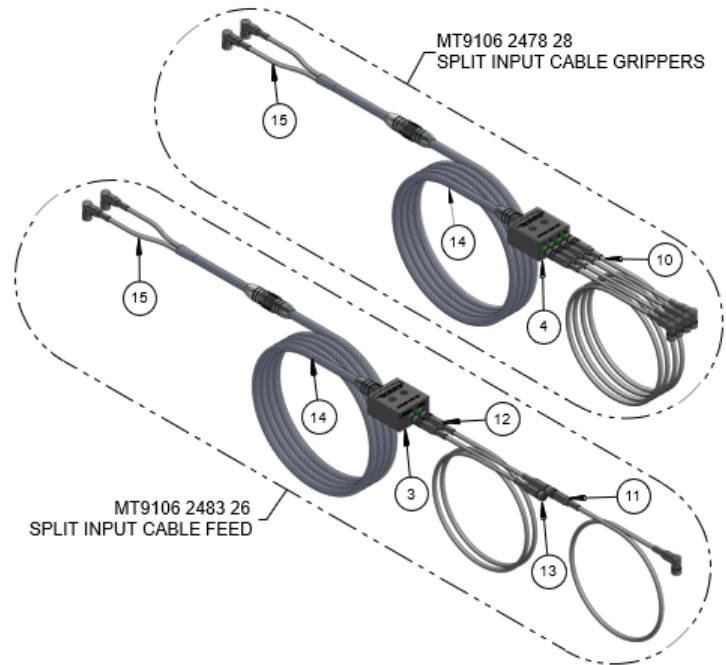

PART NUMBER	DESCRIPTION
MT3128 3158 86CA	ROD HANDLER HOSE TREE
Gavin Cunningham Ph. 0407 389 689 1 Haehy Circuit, Roseworthy S.A. 5371	
	
<a href="mailto:parts@mtunderground.com">parts@mtunderground.com</a> <a href="mailto:gav@mtunderground.com">gav@mtunderground.com</a> <a href="mailto:admin@mtunderground.com">admin@mtunderground.com</a> <a href="http://www.mtunderground.com.au">www.mtunderground.com.au</a>	
PAGE	1.9

UNDERGROUND DRILL RELIABILITY